

Lecture 26
COMBENATED STRESSES
(part 1)

Assos. Prof. A. Kutsenko



Plan of lection

- **1. Classification of combined stresses**
- **2. Combined bend and tension or compression**
- **3. Example of beam calculation on bend and tension**

Classification of combined stresses

A combined stresses is called such a stress state of building that can be replaced by a combination of the simplest kinds of deformations

In engineering calculations, combined stresses may be classified into the following four main types:

- **combined bending and tension or compression;**
- **a complex bending;**
- **the off-centre acting of force of tension or compression;**
- **combined bending and torsion**

Combined bend and tension or compression

The case of stresses state, when in an arbitrary cross-section internal force factors are given to the normal force and to one or two bending moments are in the perpendicular planes

Combined bend and tension or compression

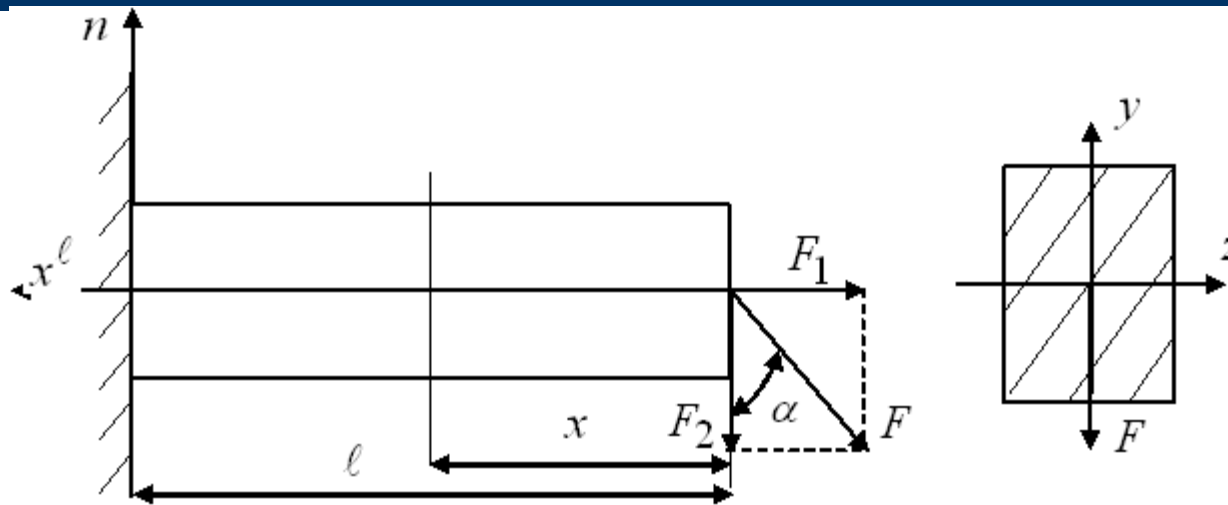

Fig. 1

Consider the problem of determining the normal stresses in arbitrary cross-section of a straight beam of big stiffness (Fig. 1), when we have direct transverse bending by force F_2 and simultaneously tension by force F_1 .

Combined bend and tension or compression

Since the beam has a constant cross-sectional shape, the value of normal stresses in arbitrary cross-section is determined by the formula:

$$\sigma_N = \frac{N}{A} \quad (1)$$

The stresses by bending moment which are caused by force are determined by the formula:

$$\sigma_y = \frac{M_x \cdot y}{I_z} \quad (2)$$

Combined bend and tension or compression

Then the magnitude of total stresses, due to the principle of the independence acting of forces, at an arbitrary point of the cross-section of the beam, will determine from:

$$\sigma = \sigma_N + \sigma_y = \frac{N}{A} + \frac{M_x \cdot y}{I_z} \quad (3)$$

Combined bend and tension or compression

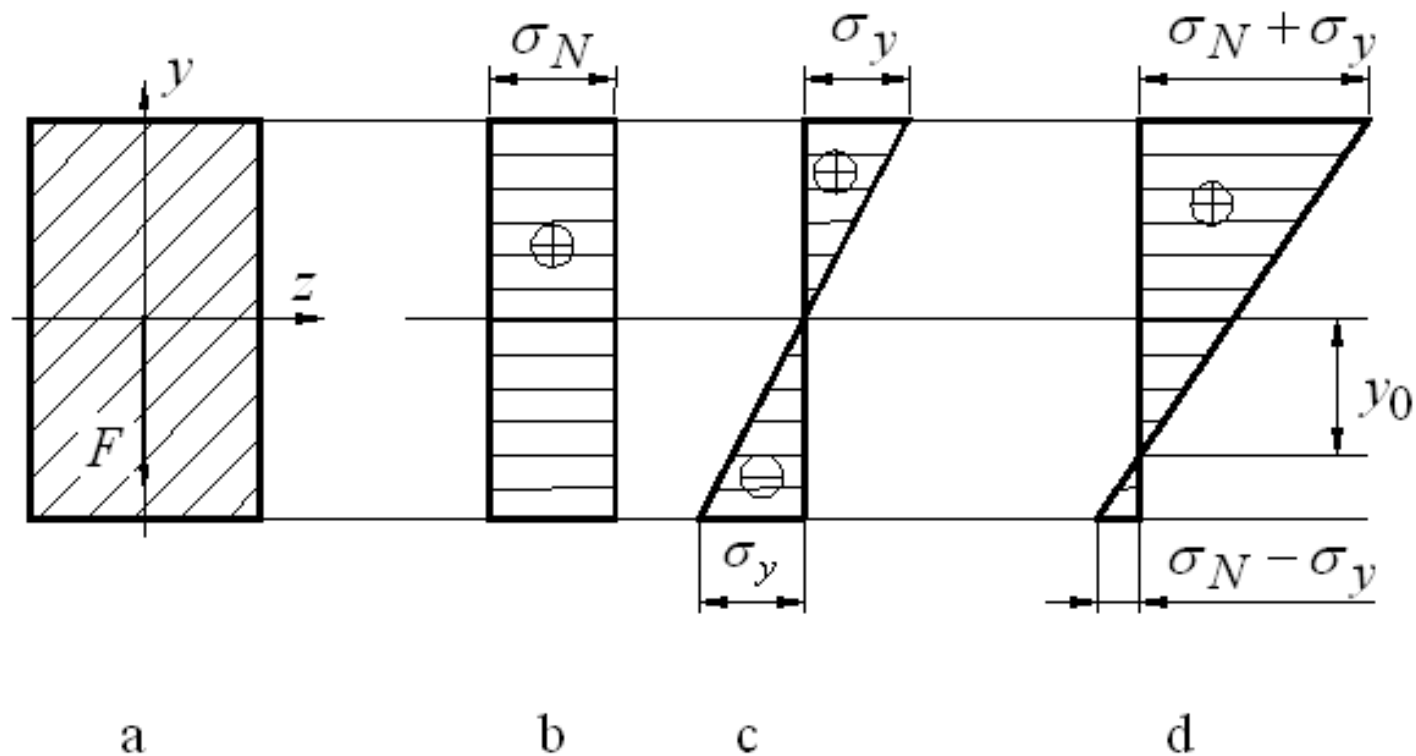

Fig. 2

Combined bend and tension or compression

Let us define a new position of the neutral axis of the cross section relative to the centroid of the section:

$$\frac{N}{A} + \frac{M_x \cdot y}{I_z} = 0$$

where

$$y_0 = -\frac{N}{A} \cdot \frac{I_z}{M_x} \quad (4)$$

Combined bend and tension or compression

The strength condition of the beam, which is based on the magnitude of normal stresses in the dangerous cross-section, in the place of fixing, and will take the form:

$$\sigma_{\max} = \pm \frac{N}{A} \pm \frac{M_x}{W_z} \leq [\sigma] \quad (5)$$

Example

Let $q=10$ kN/m; $M=20$ kNm; $\alpha=60^\circ$

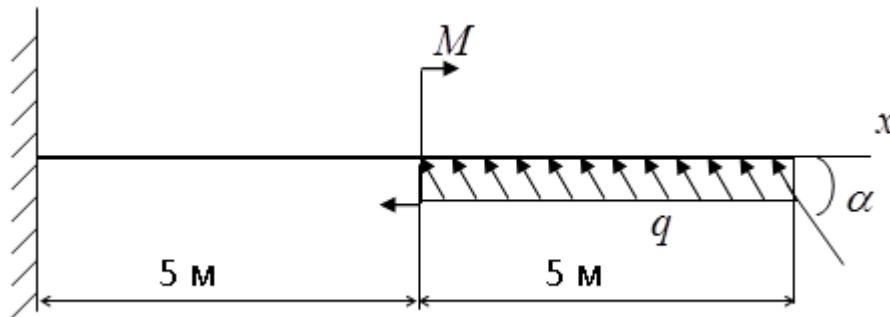

Fig. 3

Calculate the double T-beam cross-section of the beam

Example

The diagram of normal force for given beam

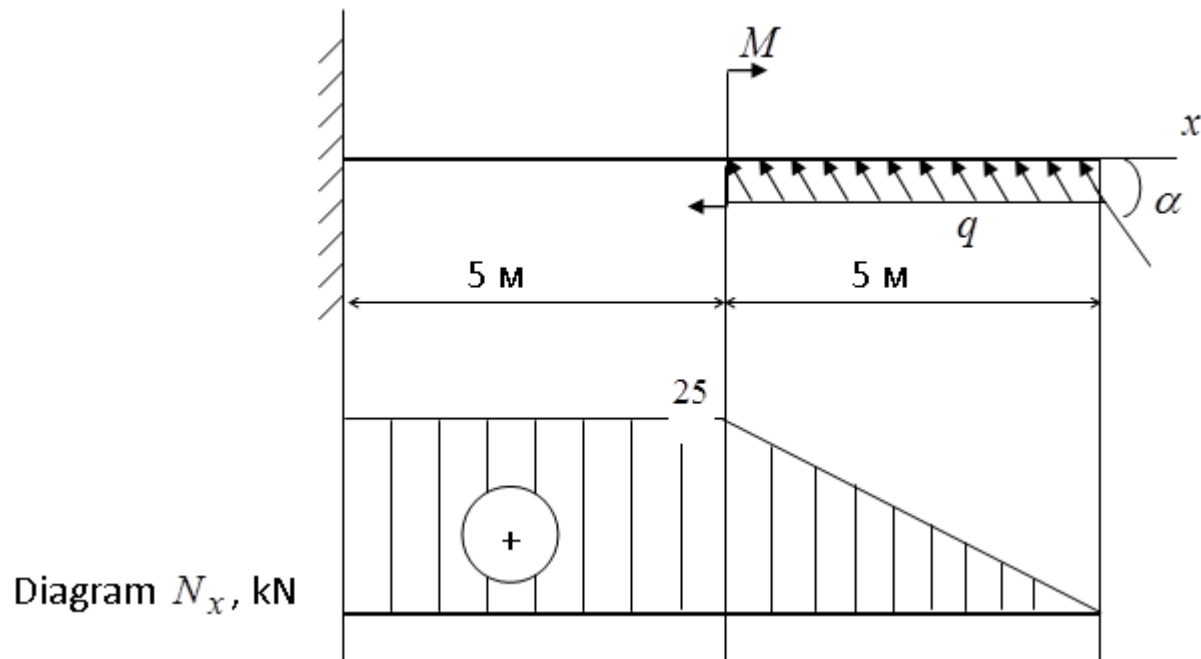
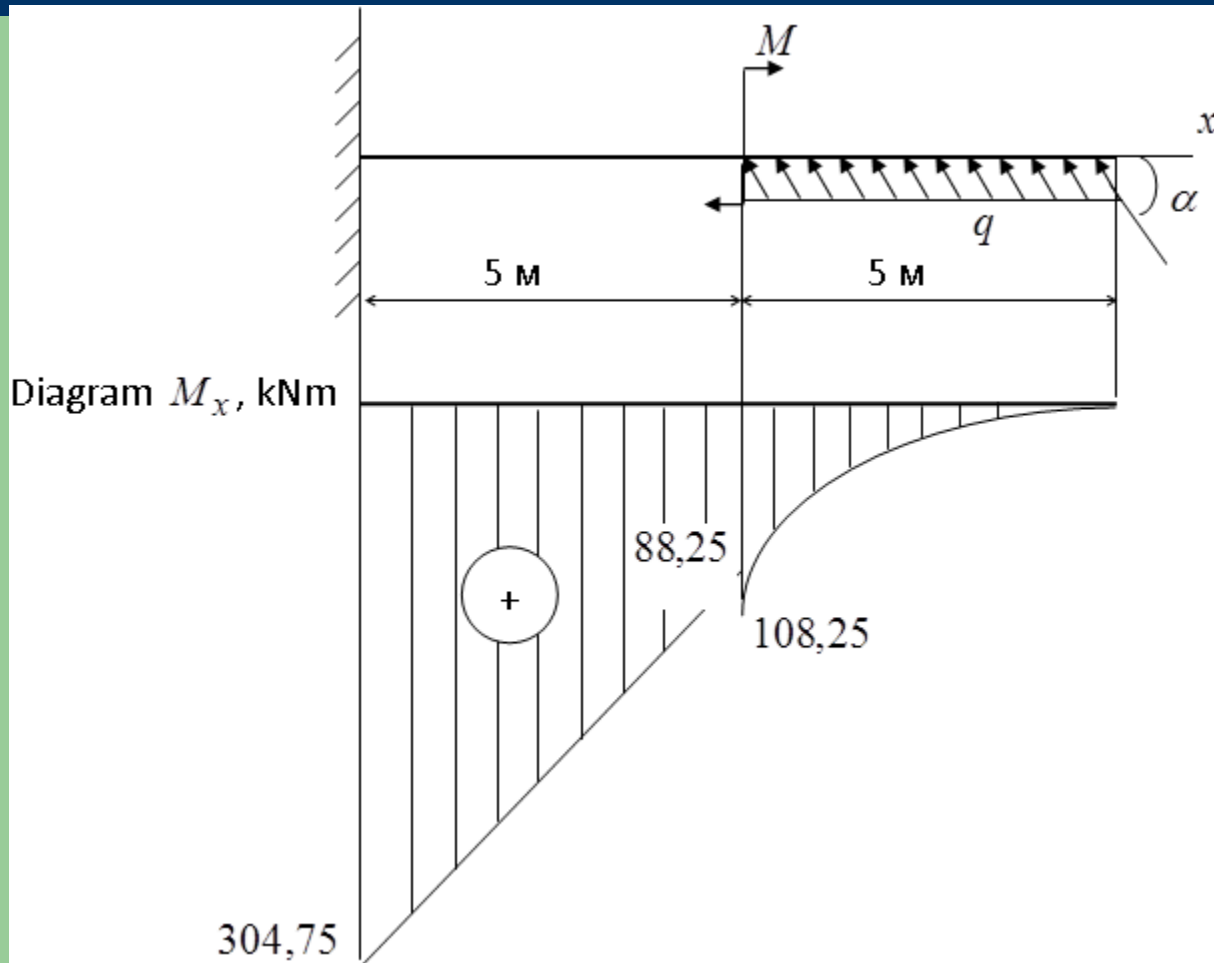

Fig. 4

Example



The diagram bending moment for given beam

Fig. 5

Example

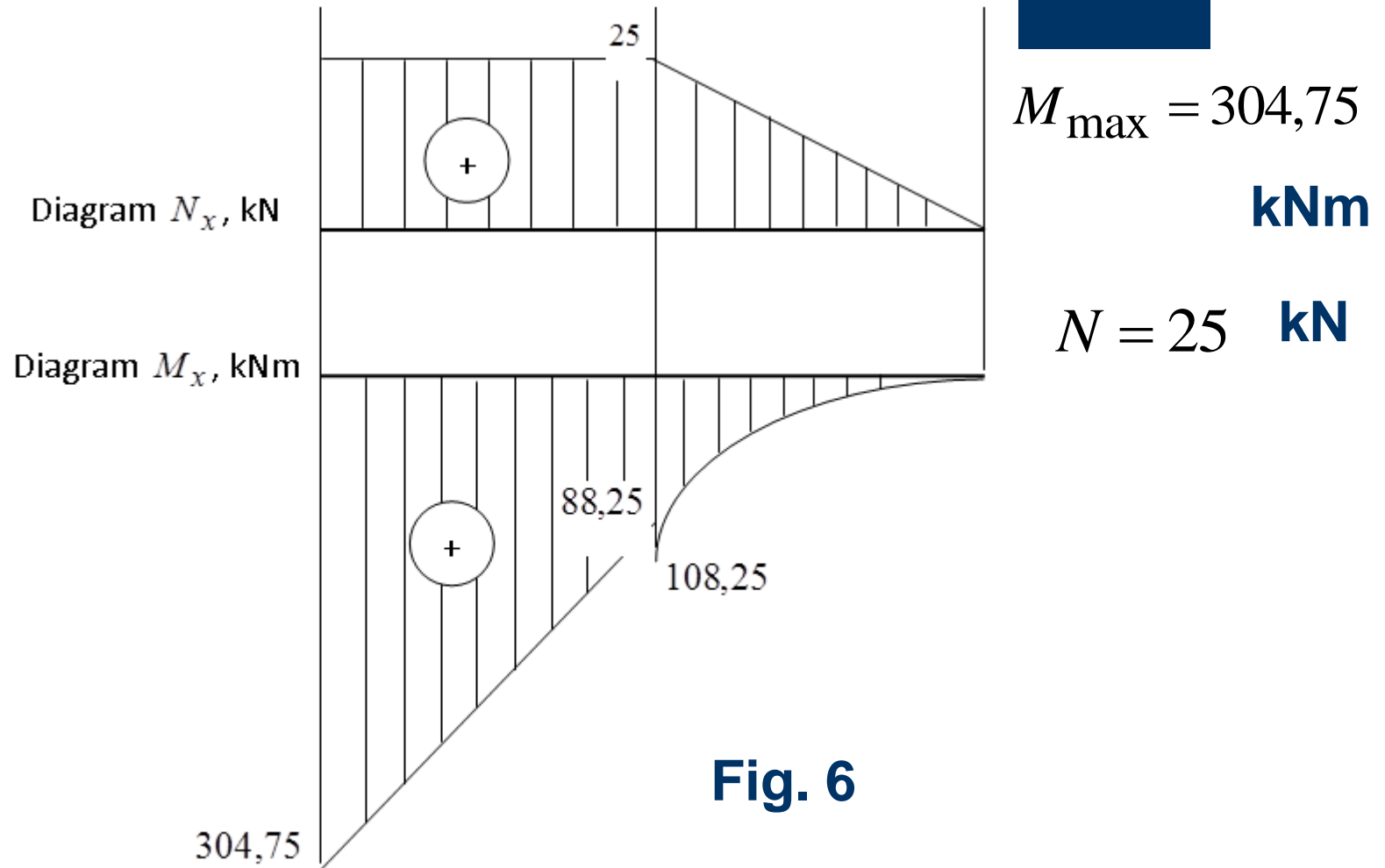

Fig. 6

Example

The the condition of strength is:

$$\sigma_{\max} = \frac{304,75 \cdot 10^{-3}}{W_z} + \frac{25 \cdot 10^{-3}}{A} \leq 160 \text{ MPa}$$

Let us calculate dimensions of the cross-section from the bending:

$$W_z \geq \frac{304,75 \cdot 10^{-3}}{160} = 1905 \cdot 10^{-6} \text{ m}^3$$

Example

From the table sorts of steel we choose double T-beam № 55. For it we have:

$$W_z = 2035 \text{ cm}^3 \quad A = 118 \text{ cm}^2$$

Checking on the strength of the beam by the formula :

$$\sigma_{\max} = \frac{304,75 \cdot 10^3}{1905 \cdot 10^{-6}} + \frac{25 \cdot 10^3}{118 \cdot 10^{-4}} = (149,8 + 2,1) \cdot 10^6 = 151,9 \text{ MPa}$$

Example

The beam is not loaded with:

$$\frac{160 - 151,9}{160} 100\% = 5,1\%$$